

# Spectrum Plus™ Series Telephone User's Guide

SINGLE LINE DIGITAL CENTREX  
SPEAKERPHONE TELEPHONE  
MODEL DC550

This page is intentionally left blank

# Introduction

Congratulations on your purchase of the TeleMatrix Spectrum PLUS™ Series DC640 Digital Centrex. The DC550 includes advanced features that are suitable in today's business environment. The DC550 is equipped with preprinted feature/line keys which can be used to customize your telephone features and line appearance.

TeleMatrix designed the DC550 to be simple to install and easy to use. The DC550 is for use behind a Nortel Meridian Digital Centrex environment provided by your local telephone company. It has a two line LCD display which displays local business telephone features and switch features that are provided by your telephone service provider. Switch features must be ordered from your local telephone provider. Local features provide you the convenience of customizing your DC550 telephone for your personal use.

The DC550 Digital Centrex Telephone is a precision electronic device that requires minimum maintenance. Please be sure to read the contents set forth in the user's guide to become familiar with connecting and the functionality of this product.

Contact your Telephone Administrator or your Local Telephone Customer Service Representative for proper set up of your telephone network.

## Compliance and Safety

As specified by FCC regulation, we are required to inform you of specific governmental and compliance regulatory requirements, safety notices, safety instructions and other informative information. TeleMatrix, Inc. provides this information in a separate manual. We pack the separate Compliance and Safety Manual within each outer box or product box when shipped.

Prior to reading this operation manual and prior to setting up your telephone, please refer to the Compliance and Safety Manual.

# Contents

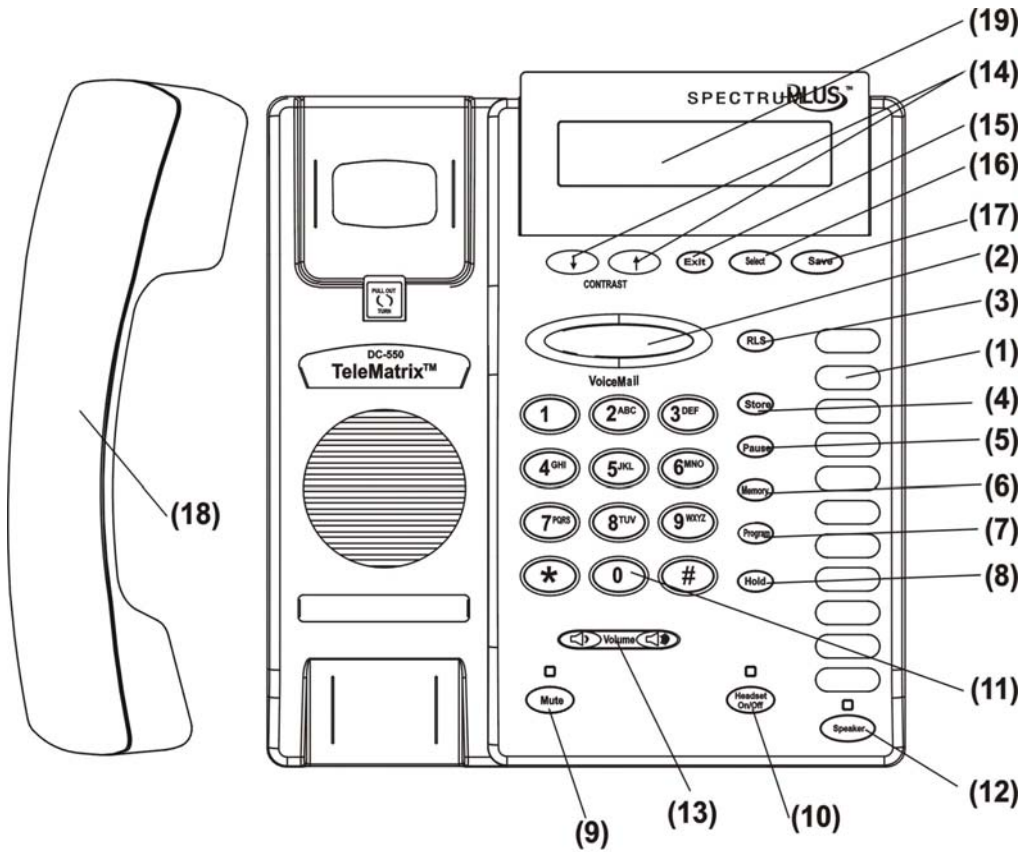
Features .....	5
Controls .....	6
Part List .....	10
Installation .....	11
Wall Mounting .....	14
Programming .....	16
LCD Display/Caller Identification .....	29
Headset Installation and Operation.....	32
Operation .....	34
Care and Maintenance .....	40
Service .....	41
Warranty .....	42

FCC Compliance and Safety Instructions, Warranty and Service Information may be found in a separate manual within this package. If these/this manual is not found in this products packaging, then immediately contact your local supplier

# Features

- Digital Centrex Operation with multi-line functionality
- SteelTrap™ Memory Technology (No Batteries Required)
- FreeSpeech™ Talk Feature: Allows Free Toggle between Handset, Headset and Speakerphone
- Eleven (11) Access Feature Keys with LED Indicators (Key #M01-M11)
- TouchLite™ One Touch Message Retrieval Key (Key #M12)
- Visual Message Waiting Indication and Visual Ringing Indicator
- Large, 2-line x 24-Character LCD Display
  - Contrast Adjustable, 16-step
  - Backlit LCD Display
  - Display for Additional Call Information
  - Programmable Date & Time
  - Programmable Date and Time Format; 12 or 24 Hour Clock
  - Ten (10) Programmable Dialing Memory Locations; 20 digit capacity
  - Elapsed Call Timer
  - Multiple Language Support; English, Spanish, and French
- LCD Display Management Keys; Up and Down Scrolling
- LCD Display Programming Keys; Exit, Select, Save
- Hands Free 2-Way Speakerphone (Half Duplex) with LED Indication
- Headset Port with ON/OFF Key (built-in Amplifier) with LED Indicator
- Speaker, Handset, Headset, and Ringer Volume Control (Soft Key Toggle Switch)
- ADA Compliant Handset with 16-step Volume Control
- Microphone Mute Key with LED Indication
- Electronic Hold Key (must be provisioned for hold)
- Programming Keys; Program, Memory, Pause, Store, Up, and Down
- Memory Review Key
- Pause Key for Programming a 1.0 Second Timing Delay
- Release Key to Disconnect Call
- On Hook Pre-dialing Feature; On Hook Dialing (User Set Up)
- User Programmable Answering Default Location; Headset or Speaker
- Programmable Primary Directory Number (PDN)
- LED Indicators show ON/OFF, Flash and Wink Key Status
- Telephone Reset Feature (removes all data)
- Wall Mount or Desktop Placement

# Controls

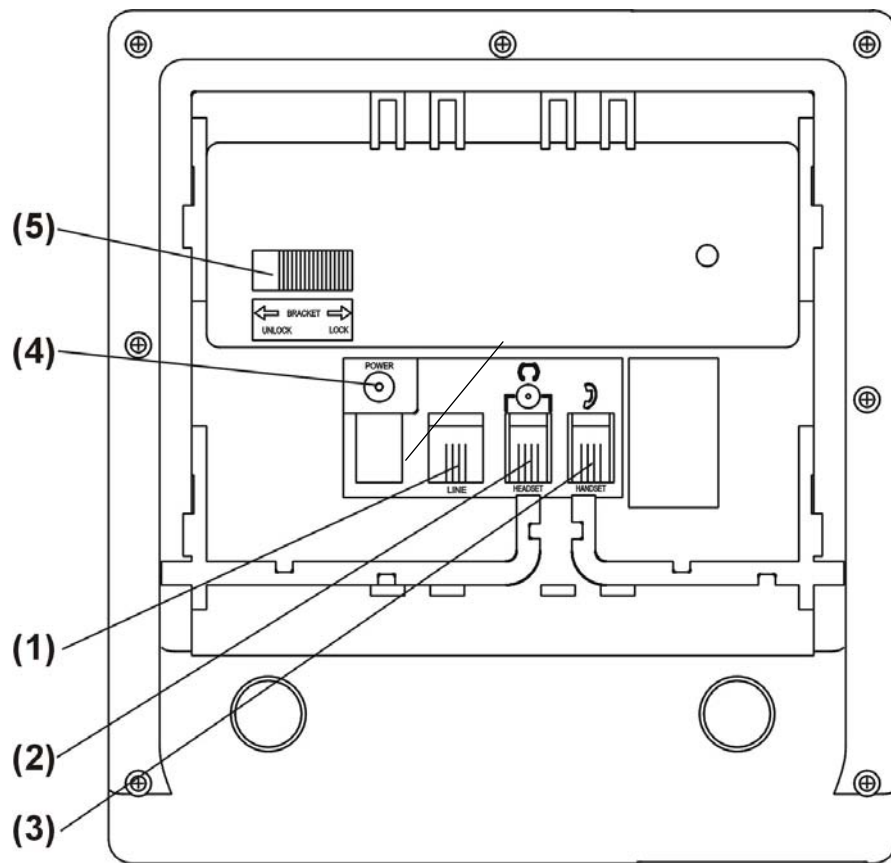


DC550 OUTLOOK

# Definition of Controls

- |                                  |  |
|----------------------------------|--|
| 1. Access Feature Keys .....     | Eleven (11) illuminated programmable on-touch keys used for line or Centrex features.  |
| 2. Touchlite™ Key.....           | Message Waiting Lamp (LED indicator) that blinks to indicate a new message in the user's voice mail box (user must be subscribed to a messaging system). |
| 3. Release Key .....             | Used to disconnect the line, place a new call or exit the programming mode.  |
| 4. Store Key .....               | Used to program a single, readily available number for later retrieval.  |
| 5. Pause Key .....               | Used to program a 1.0 second timing delay in speed dial memory or on hook dialing.   |
| 6. Memory Key .....              | Used to initiate ten (10) programmed memory locations.   |
| 7. Programming Key .....         | Used to initiate programming mode.   |
| 8. Hold Key .....                | Key used for placing callers on hold.  |
| 9. Mute Key .....                | Lighted key used for disabling the handset, headset and speakerphone microphone.   |
| 10. Headset ON/OFF Key .....     | Used to turn the headset ON or OFF. LED Indication.  |
| 11. Numeric Dial Pad .....       | Used for outbound dialing.   |
| 12. Speaker Key .....            | Used to turn the speakerphone ON or OFF. LED Indication.   |
| 13. Volume Bar .....             | Adjusts the loudness independently for the handset receiver, the headset, speaker and/or ringer.   |
| 14. Up and Down Scroll Key ..... | Used to scroll the LCD through the program menu and Memory Dial records. Also used to adjust LCD contrast.   |
| 15. Exit Key .....               | Used to exit programming mode or memory dialing mode.  |
| 16. Select Key .....             | Used for programming settings.   |
| 17. Save Key .....               | Used to save programmed settings.  |
| 18. Handset .....                | Hearing-aid compatible handset.  |
| 19. LCD Display .....            | Large adjustable backlit LCD display.  |

# Controls



# Definition of Controls

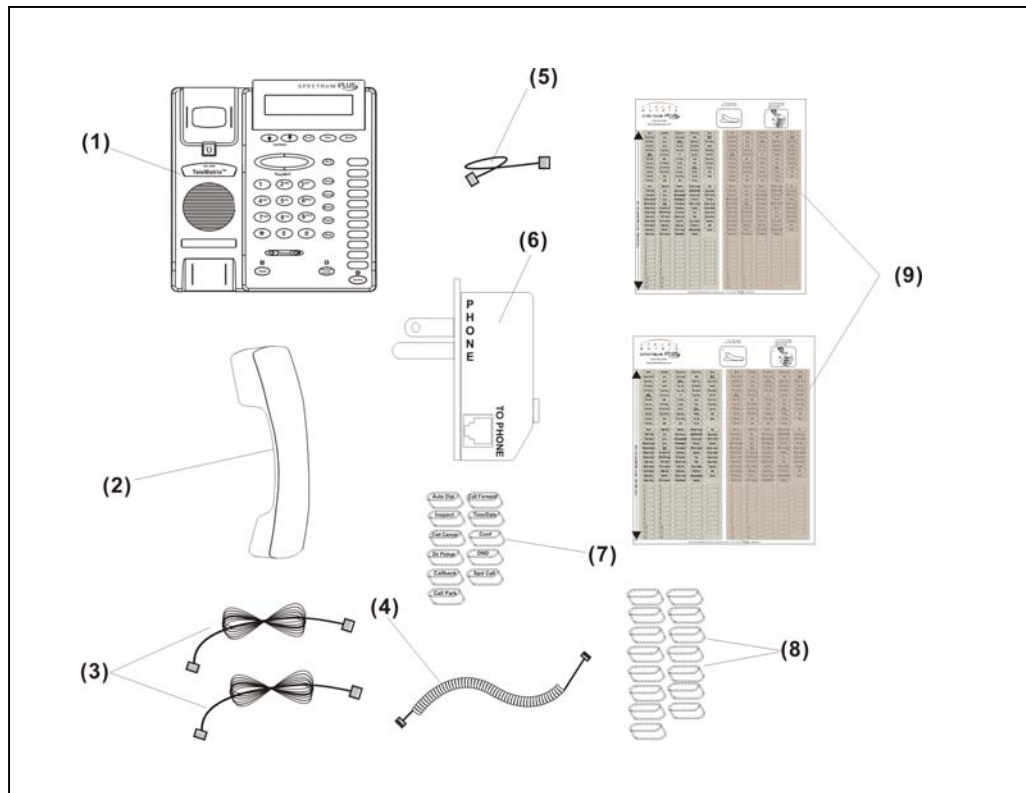
1. Line Jack ..... Modular receptacle for connecting the line cord.
2. Headset Jacks ..... Convenient RJ port or 2.5mm coaxial port used to connect an optional headset.
3. Handset Jack ..... Connection for handset coil cord.
4. Power Adapter Receptacle ..... For optional coaxial power adapter.
5. Elevation Stand Lock ..... Used to "lock" the elevation stand.

# Parts List

## Parts Check List

The following parts are included with the Spectrum PLUS™ DC550:

1. Base Unit
2. Handset
3. 15 foot Modular telephone line cords (2).
4. 10 foot Modular coiled handset cord.
5. 6 inch Modular wall mount line cord.
6. Power Adapter with Pass-Through AC Outlet.
7. Eleven (11) Preprinted Feature Keycaps
8. Fifteen (15) Clear Keycaps
9. Preprinted Feature Key Index Sheet and Blank Labels



**NOTE:** Spectrum PLUS™ Line Cords are 6-Pin 6-Conductor Line cords (6P6C line cord). Replacement Line Cords must be same.

# Installation


## Caution

- Never install telephone wiring during a lightning storm.
- Never install telephone jacks in wet locations unless the jack is specifically designed for wet locations.
- Never touch uninstalled telephone wires or terminals unless the telephone line has been disconnected at the network interface.
- Use caution when installing or modifying telephone lines.

## Power Outlet Required

The Spectrum PLUS™ Series telephone requires external power from a standard 120V outlet (60Hz). Upon loss of electrical power, the telephone will operate. All the features will work however, only the 2 bottom right keys will have LED illumination. Dial Tone will be available as long as the dial tone is available from the telephone company.

### IMPORTANT!



The telephone will not function if the line cord connections are not correct. Be sure that the telephone line cord connections are not reversed ("LINE"/"PHONE"). Attach the line cords to the power adapter and the wall before connecting to the telephone. SpectrumPLUS™ Line Cords are 6-Pin 6-Conductor Line cords (6P6C line cord). Replacement Line Cords must be the same. The DC550 is polarity sensitive. Tip and ring cannot be reversed.

# Installation

## 120V AC Outlet Recovery Power Adapter (provided)

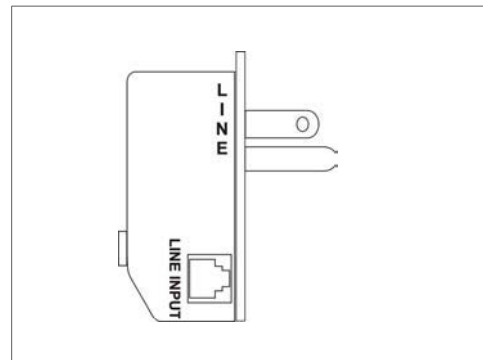
The 120 VOLT AC OUTLET ADAPTER is a proprietary TeleMatrix product. It provides both the telephone lines and the power source in one cable (6P6C line cord) and is designed to recover the use of the AC power outlet.

### Connector Configuration

The 120V Outlet Recovery Power Adapter has two (2) modular jacks. One jack is labeled "LINE INPUT" and the other jack is labeled "TO PHONE". These jacks allow for a fully modular installation.

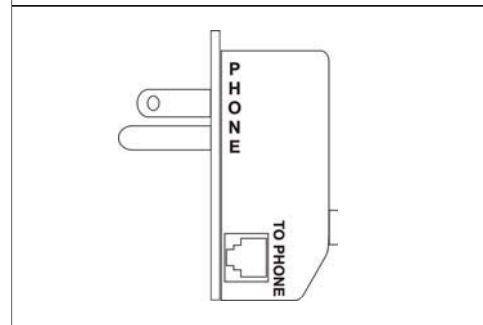
### Power Adapter "LINE" Connection

The power adapter's "LINE INPUT" connection is used to connect the telephone line from the wall jack to the power adapter. Using one of the 15-foot modular telephone line cords, connect one end of the cord to the RJ14 telephone jack on the wall or base board. The remaining end of the line cord plugs into the "LINE" side of the power adapter.



### Power Adapter "PHONE" Connection

The power adapter "TO PHONE" connector is used to provide both the telephone line and the power source to operate the telephone. Using one of the 15-foot modular telephone line cords, plug one end of the line cord into the back of the telephone. Plug the remaining end to the power adapter jack labeled "TO PHONE".

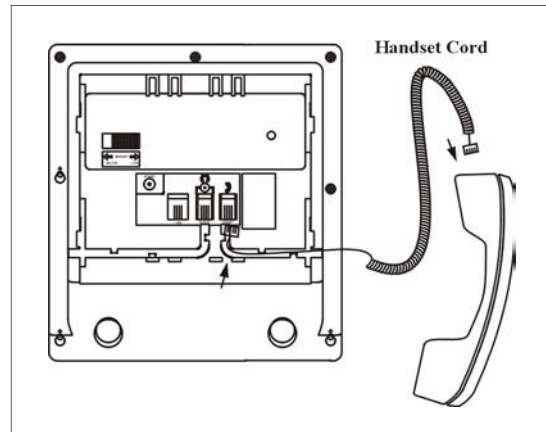


**Troubleshooting Note:** If there is no power to the telephone after connecting the line cords, check to see if the line cords were inserted in the opposite sides of the adapter.

# Installation

## Connecting the Handset Cord

A 10-foot modular coil handset cord is provided. (*Be sure that the wall/desk elevation stand has not been attached*). To install the cord, simply plug the *short straight* end of the handset cord into the modular jack on the handset. The *long straight* end of the handset cord plugs into the jack labeled "Handset" located on the bottom of the SpectrumPLUS™ base unit. Place the line cord into the handset coil cord channel located directly below the jack.



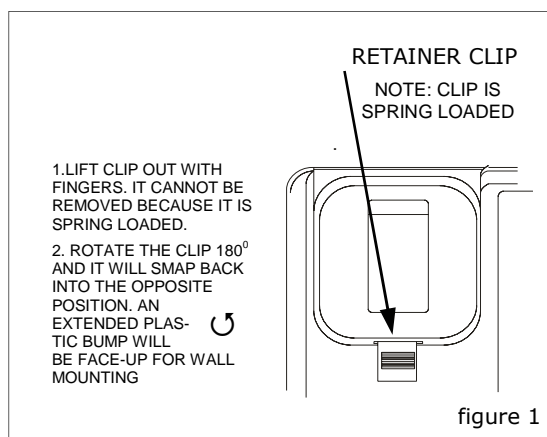
**NOTE:** Be sure that all line cord connections are made prior to installing the Wall Mount Wedge. An optional direct connect coaxial power supply can be used or the provided power supply can be used.

## Wall Mounting the Spectrum PLUS™ Telephone

The Spectrum PLUS™ was designed to be conveniently wall mounted without requiring additional hardware.

Follow these easy steps:

1. The handset retaining clip must be in the correct position to secure the handset into the handset cradle. Engage the clip with your fingers and pull the clip forward (towards you), rotate the clip 180° and snap the clip back into place (figure 1). The retaining clip cannot be removed.



# Installation

## Wall Mounting the Spectrum PLUS™ Telephone (continued)

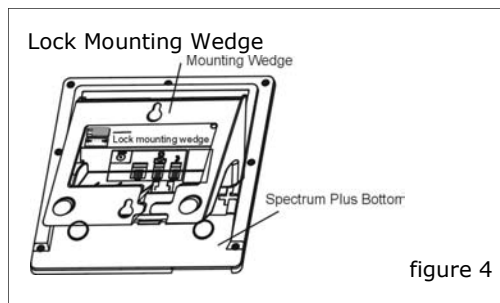
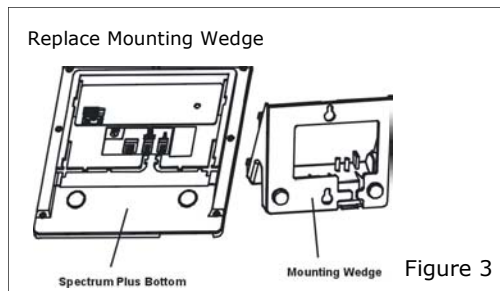
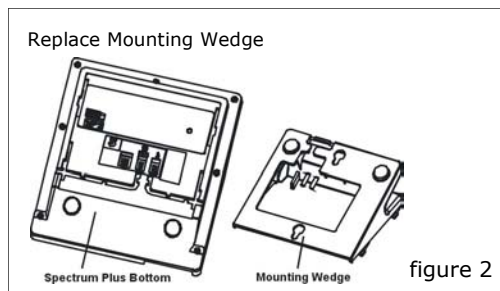
2. The Spectrum PLUS™ has provisions for a mounting wedge that must be correctly positioned. This wedge allows the telephone to be viewed at a correct angle when the phone is wall mounted. Remove the wedge from the phone base (figure 2).

3. Secure the line cord, coil cord and any wiring in place prior to installing the wall mount wedge. The wall mount base has extra large wiring channels and strain relief poles for containing the wires in a neat and orderly way. Wrap the wires around the strain relief poles and then secure the wires through the channel.

4. To wall mount, place the narrow edge at the top edge of the phone base and slide the wedge upward into place (figure 3).

5. Lock the wall mount into position by sliding the locking button to the right (figure 4).

**Note:** A 6-inch line cord is provided for when the telephone is to be wall mounted. Connect one end of the line cord to the phone jack and the other end to the wall jack. Be sure to connect the power cord and line cords before placing mounting wedge on the bottom base. An optional coaxial power supply can be used in place of the supplied power supply. See your local distributor for information.



## Desk Mounting

To install the wedge for desk mounting, be sure the lock mechanism is positioned to the left, clear of the locking arm. Place the wedge in the slots, wide end toward top of phone base unit, and slide the wedge upward into position. Lock the wedge into place.

# Installation

## Installing Access Feature Keycaps

Eleven (11) pre-printed access feature keycaps are provided for placement on the access feature keys. These keycaps identify the keys use. There are 15 clear keycaps provided for printed labels to be inserted.

To install the pre-printed keys, simply remove the clear keycap by pulling it up with a fingernail or sharp object. Replace with the pre-printed keycaps or place hand-written paper index sheets under a clear keycap. Position the keycap onto the key and press downward to snap the keycap on. (figure 1)

Contact your local telephone administrator for specific instructions of the keys to use and their location.

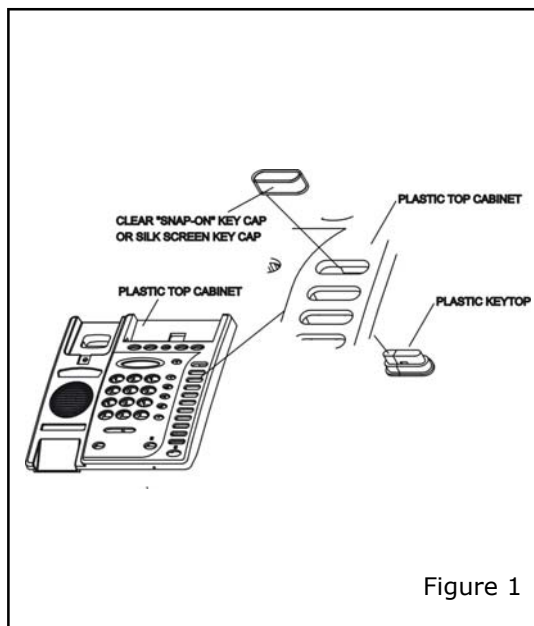


Figure 1

## Key Selections (Printed on labels)

Agent	Call Supv	EMK	Make Busy	Queue
Agent Avail	Call Wait	Emergency	MCH	Queue Status
Agt Status	Conf	End To End	Night Serv	Query Busy
Ans Agent	Conf 3	Exec Msg Wtg	Not Ready	Redial
Ans Emergency	Conf 6	Flex Call	Obs Agent	Ring Again
Auto Callback	Conf/Transfer	Force Call	Override	Spd Call
Auto Dial	Cwt Cancel	I/C	Park	Supervisor
Auto Line	DND	I/C Group	Page	Time/Date
Call Agent	Dir Pickup	In Calls	Pwr Features	Transfer
Call Fwd	Dis Agt Sum	Inspect	Pickup	UCD
Call Park	Disp Queue	Interflow	Priv Rls	Wake
	Drop	Leave Msg	Privacy	
		LOB		

# Programming

## Programming Keys

The Spectrum PLUS™ DC550 supports the Nortel Meridian Digital Centrex System Environment. The following pages show diagrams on how to program different features of the telephone.

Simply follow the instructions on the LCD screen. The keys below are used to program the telephone.

### **PROGRAM KEY (located on base)**

To enter into the programming mode, press the “PROGRAM” key.

### **EXIT KEY\***

To exit the program mode, press the “EXIT” key.

### **SELECT KEY\***

To select the feature needing to be programmed and advance the LCD screen to the next screen, press the “SELECT” key.

### **SAVE KEY\***

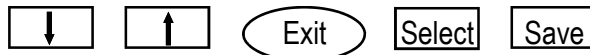
To save the feature selected, press the “SAVE” key.

### **ARROW KEYS\***

Use the “UP” and “DOWN” keys to scroll through the Programming Menu or Memory Dial records.

### **\* LCD Display Information Management Keys**

The Spectrum PLUS™ is equipped with five Liquid Crystal Display (LCD) Management Keys that are used to support programming of the telephones and to scroll through the displayed information.



- Programming must be done with the power adapter plugged into the wall.
- Programming must be performed with the telephone on-hook.
- A maximum of 20 digits can be entered into each memory dial locations, including Pauses.

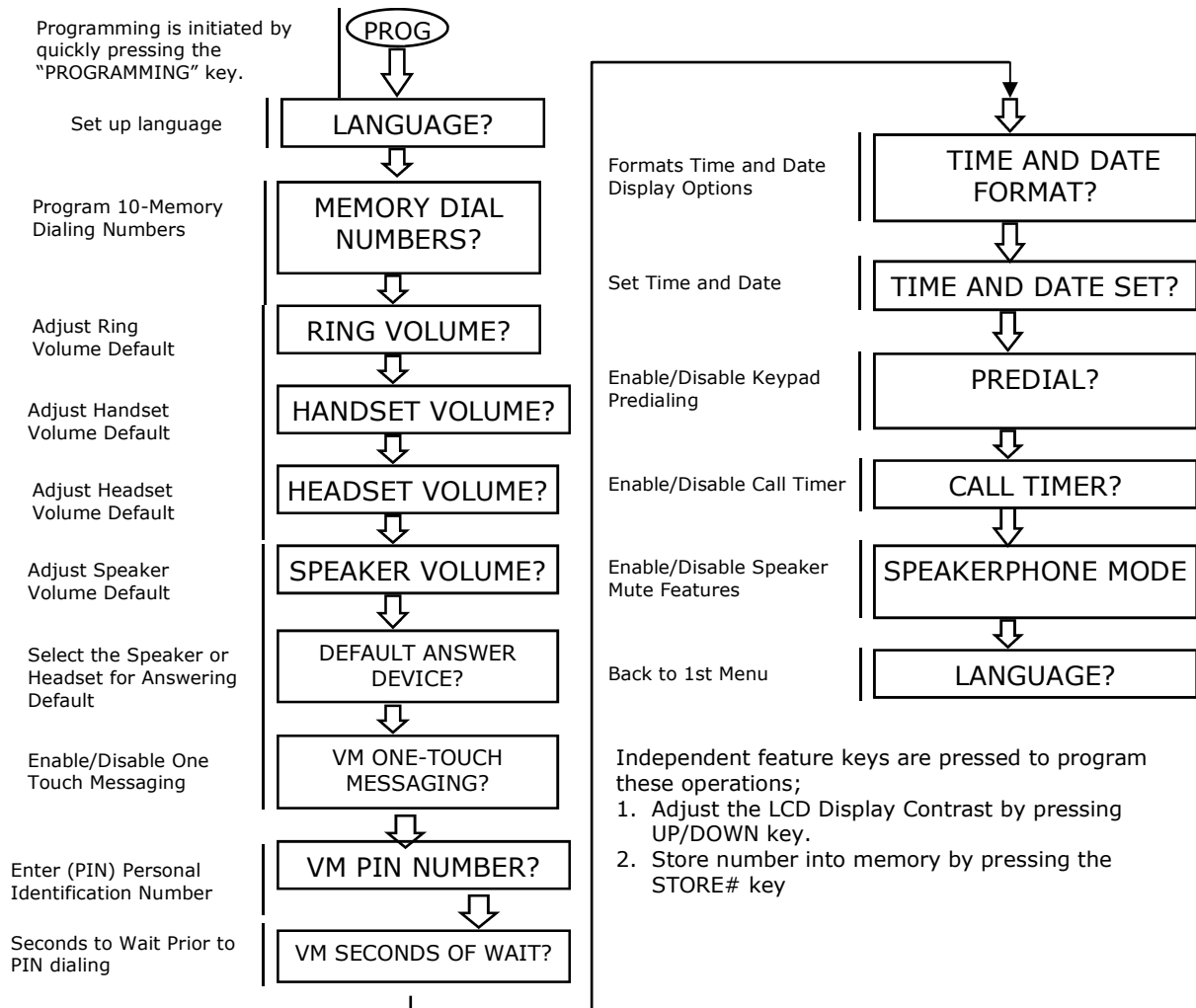
# Programming

## Programming Local User Preferences

The Spectrum PLUS™ DC550 requires simple initial programming that allows the user to personalize the telephone setup.

### Quick Program Guide

The Spectrum PLUS™ DC550 Quick Programming Guide is a summary list of set up options. Additional detailed instructions are provided in the manual.



# Programming

## Programming Central Office (C.O.) Features

Central Office (C.O.) features must be activated by your local telephone administrator or local telephone company Customer Service Representative. Once this is complete, simply label the Active Feature Keys to match the programmed C.O. features.

The Spectrum PLUS™ Telephone allows for eleven (11) programmable advanced feature keys to interact with the local telephone Digital Centrex network. The call out of these keys have been determined by your local telephone administrator or telephone company Customer Service Representative. The programming is done by the Central Office supporting the Digital Centrex Environment.

## Programming the Speed Call / Dial Feature Key

A popular feature of The Spectrum PLUS™ DC550 is Speed Calling. Once it is programmed by the Central Office, this advanced feature allows you to dial a telephone number using one or two digits on the keypad. Speed Call/Dialing allows you either 10 one-digit codes (0-9) or up to 70 two-digit codes (00-69). To find out what code types are available to you contact your local telephone administrator or Customer Service Representative. The dialing formats are programmed by the Central Office who supports the Digital Centrex Environment.

## Programming the Message Waiting (MW) Indicator Light

Another popular Spectrum PLUS™ DC550 feature is the Voice Mail and Message Waiting (MW) Light Indicator. It is a dual function button. One use is for Message Waiting Indication indicator that will blink repetitively to indicate that a new message is in the user's voice mailbox.

The other purpose allows the user to simply press the Touchlite™ button key to connect automatically into their voice mail. When this feature key is programmed properly, the PIN number dialing is delayed until after the messaging service requests a password. Voice Mail (VM) requires provisioning at the Central Office but the wait time and PIN are programmed by the user into the DC550. The Digital Centrex telephone service provider has to activate the voice mail feature for the light to illuminate and work properly.

## Programming Other System Features

There are many system features the Digital Centrex telephone service offers. These are required to get the telephone features to function. Like most business entities that use the Digital Centrex environment, the feature choices are pre-determined and pre-programmed into your telephone network system. Your local telephone administrator or local telephone company Customer Service Representative will answer these questions about your C.O. services and provisioning of these features. The telephone will interact with the feature choices you make once the programming is completed within the telephone's network environment.

# Programming

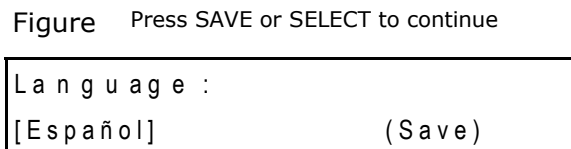
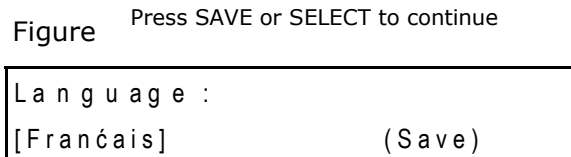
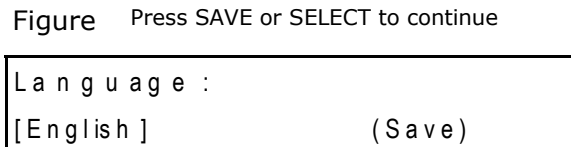
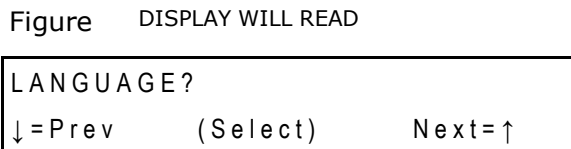
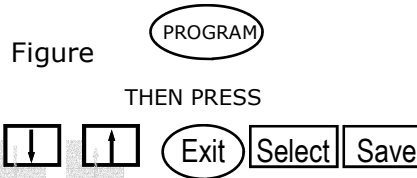
## Programming Users Telephone Features

The Spectrum PLUS™ DC550 allows for the user to customize the telephone to the user's preference when operating. The following pages provide instructions on how these options are programmed.

### Setting Up Language

The telephone LCD has the ability to display 3 languages: English, French, and Spanish.

1. Press the **"PROGRAM"** key ( Figure 1). Press the **"UP"** or **"DOWN"** key until the display reads **"LANGUAGE?"** (Figure 2).
2. To activate, press the **"SELECT"** key (Figure 3).
3. The LCD will display **" ENGLISH"**. Press the **SAVE** key or press the **"UP"** or **"DOWN"** key to continue . French or Spanish are the remaining options (Figure 4a, 4b, 4c).
4. Press **"SAVE"** when the correct language is displayed.
5. Press **"EXIT"** to exit the program mode or press **"UP"** or **"DOWN"** to continue scrolling through the program mode.



# Programming

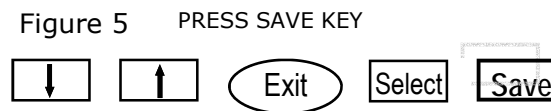
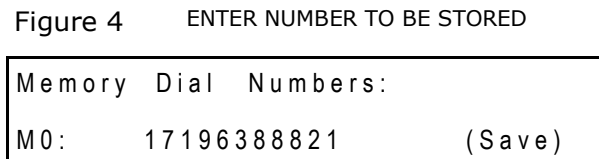
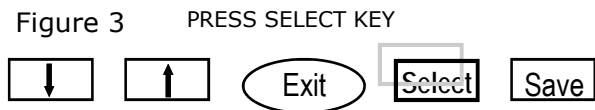
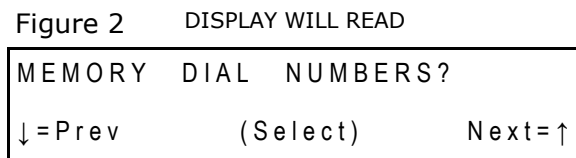
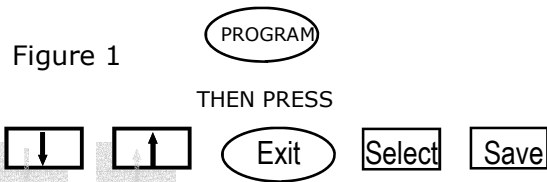
## Programming the Stored Record Memory

The Spectrum PLUS™ DC550 allows for up to ten (10) number records to be stored in the LCD memory for frequently dialed calls. This section describes the programming for the ten (10) LCD Memory locations. These programmed numbers will be saved in LCD Memory.

### Programming Location Memory Records

The telephone has the ability to store 10 telephone numbers into memory for future dialing.

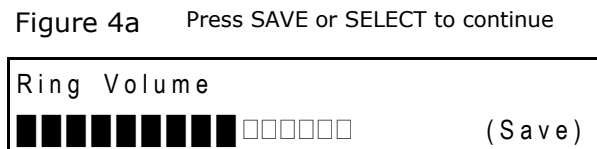
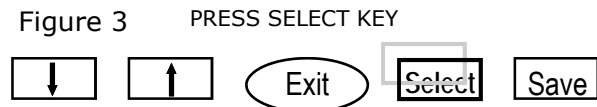
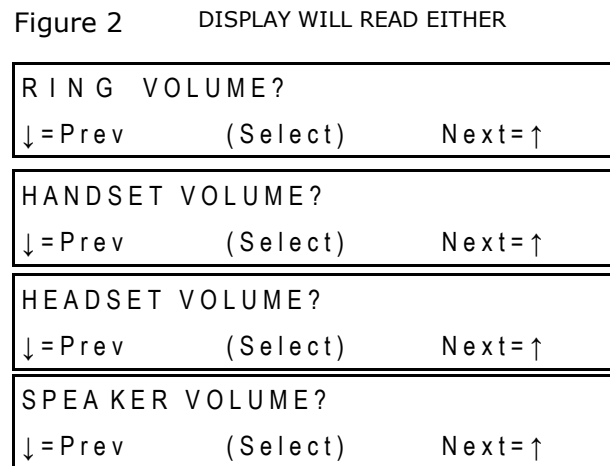
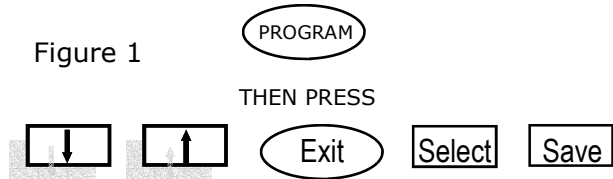
1. Press the **"PROGRAM"** key (Figure 1). Press the **"UP"** or **"DOWN"** key until the display reads **"MEMORY DIAL NUMBERS?"** (Figure 2).
2. To activate, press the **"SELECT"** key (Figure 3).
3. Select a memory location by scrolling through the LCD Display. Enter the number to be saved. Be sure to enter a "1" and area code when required by your area telephone company (Figure 4).
4. Press **"SAVE"** to save the number in memory. Note that the first saved record will be stored in location "M0". The second and third records will be stored in "M1", "M2" ... "M09" locations (Figure 5).
5. Press **"EXIT"** to exit the program mode or press **"UP"** or **"DOWN"** to continue scrolling through the program mode. (Figure 6)



# Programming

## Programming Volume (Alerter, Speaker, Headset or Handset)

1. Press the **"PROGRAM"** key (Figure 1). Press the **"UP"** or **"DOWN"** key until the display is on the correct **"VOLUME?"** program, i .e. Ri ng, Spe aker, Headset or Handset (Figure 2).
2. To ac tivate, pr ess the **"SELECT"** key (Figure 3).
3. The LCD will display the current settings. Pr ess t he U P/DOWN Key to adjust the volume.
4. Press **"SAVE"** when the correct volume is displayed.
5. Press **"EXIT"** to exi t the pro - gram mo de or pre ss **"UP"** o r **"DOWN"** t o c ontinue s crolling through the program mode.

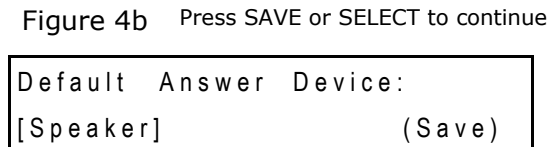
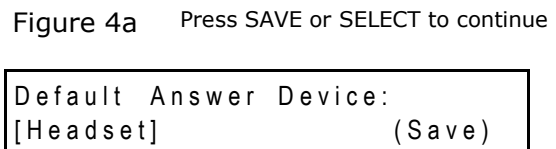
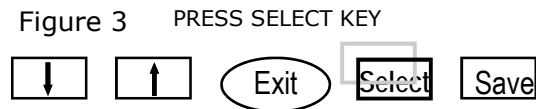
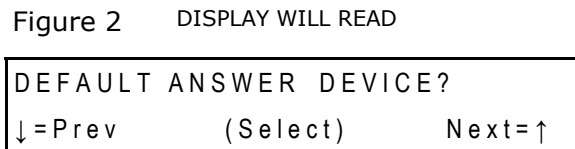
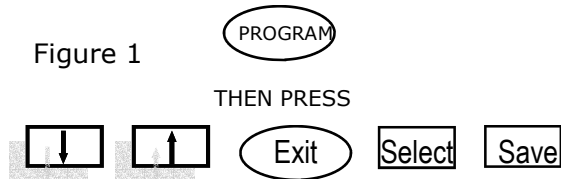


# Programming

## Programming Default Answer Device (Headset or Speaker)

When the user presses the line key (i.e. the bottom most Feature Key) the phone will be required to pick up on either the headset or the speakerphone if the handset is on hook. For example, a receptionist might choose to auto answer calls on a headset, while someone working in a private office might prefer the speakerphone. The Default Answer Device Menu allows the user to choose between the headset and speakerphone for these scenarios.

1. Press the **"PROGRAM"** key (Figure 1). Press the **"UP"** or **"DOWN"** key until the display shows **"DEFAULT ANSWER DEVICE?"** (Figure 2).
2. To activate, press the **"SELECT"** key (Figure 3).
3. Select either **"HEADSET"** or **"SPEAKER"**. This activates whether the HEADSET or SPEAKER is the primary answering device. By selecting SPEAKER the primary answer device includes the handset and speaker (Figure 4a, 4b).
4. Press **"SAVE"** when the correct default is displayed.
5. Press **"EXIT"** to exit the program mode or press **"UP"** or **"DOWN"** to continue scrolling through the program mode.



# Programming

## Programming Voice Mail

Using the One-Touch Messaging feature, the Voice Mail advanced feature key can be pressed to connect to the Voicemail system on the Nortel Meridian PBX or Central Office switch. The switch must be provisioned for voice mail on the 12th key.

The program allows for up to 20-digits. The digits of the Personal Identification Number (PIN) will appear on the LCD as they are entered, but will not appear after they are saved. The VM Pin Number menu will show an asterisk in place of each digit.

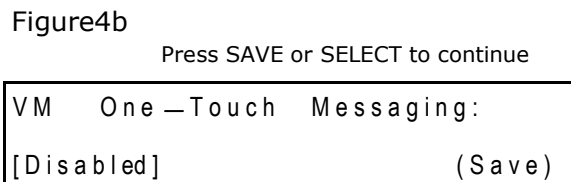
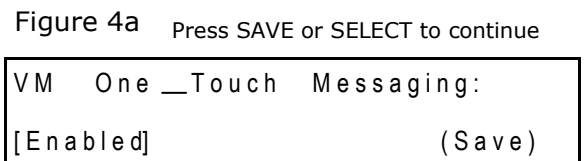
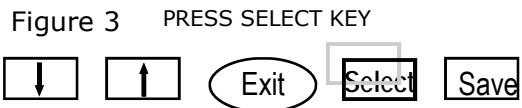
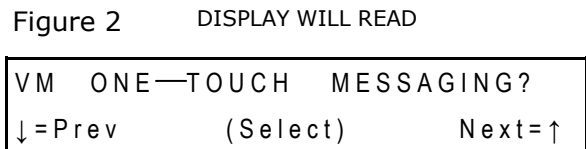
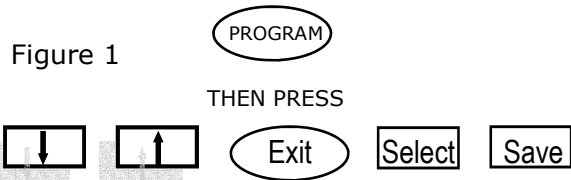
The VM PIN Number Menu will appear only if the One-Touch Messaging feature is enabled.

The VM Seconds of Wait menu will also appear only if the One-Touch Messaging feature is enabled. This is the amount of time that the telephone waits when the Voicemail key is pressed and when the PIN Number is dialed.

1. Press the **"PROGRAM"** key ( Figure 1). Press the **"UP"** or **"DOWN"** key until the display shows **"VM ONE TOUCH MESSAGING?"** (Figure 2).
2. To activate, press the **"SELECT"** key (Figure 3).
3. Select either **"ENABLE"** or **"DISABLE"**. Selecting **ENABLE** activates One Touch Messaging (Figure 4a, 4b).

Note: If feature key number 12 is provisioned in the DMC as the voice mail key, pressing the key will activate voicemail regardless if one-touch messaging is enabled or not. However, when one-touch messaging is enabled, the PIN number will always be dialed. The PIN number can be left blank (non-programmed).

4. Press **"SAVE"** when the correct default is displayed.



# Programming

## Programming Voice Mail: Seconds of Wait and PIN Number

1. Once the VOICE MAIL “**VM ONE TOUCH MESSAGING?**” is **ENABLED**, press the “**UP**” or “**DOWN**” key to get the sub menu. “**VM PIN NUMBER:**” (Figure 1).
2. Press SELECT (Figure 2).
3. Enter your personal identification number (PIN) that will be used to retrieve your voice mail messages. In programming mode, the PIN number will be shown but once saved, the PIN will be shown as asterisks (Figure 3).
4. Press SAVE (Figure 4).
5. Press the “**UP**” or “**DOWN**” key to display “**VM Second of Wait**”. Seconds of Wait allows for a 0 to 99 second time delay before the telephone memory will dial the preprogrammed personal identification number (PIN) (Figure 5). The timing will need to be tested with the specific voice mail service to ensure the correct amount of seconds is programmed. The timed delay to program into memory is dependent on when the voice mail answers and requests a PIN number. To determine this time, make a trial call to your Voice Mail and time the voice mail service.
6. Press the SELECT key (Figure 2). Enter the number of seconds to wait using the keypad. The number will be displayed on the LCD. The range is 0–99 seconds (Figure 6).
7. Press “**SAVE**”.

Figure 1 DISPLAY WILL READ

```
VM PIN NUMBER?  
↓=Prev (Select) Next=↑
```

Figure 2 PRESS SELECT KEY



Figure 3 DISPLAY WILL READ \*, ENTER PIN

```
VM PIN Number:  
*****  
VM PIN Number:  
1 2 3 4 5 6
```

Figure 4 PRESS SAVE KEY



Figure 5 DISPLAY WILL READ

```
VM SECONDS OF WAIT?  
↓=Prev (Select) Next=↑
```

Figure 6 PRESS SELECT, ENTER SECONDS

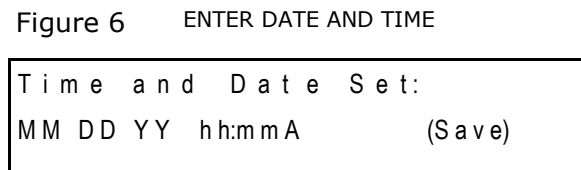
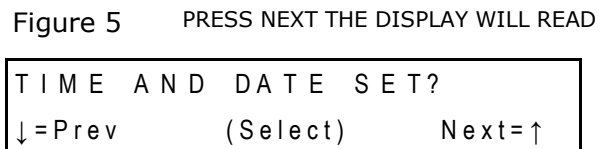
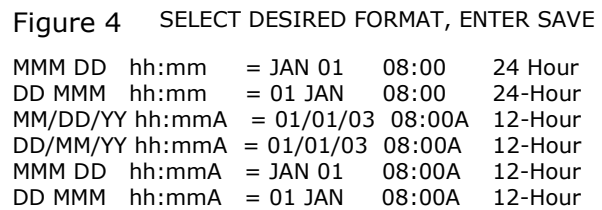
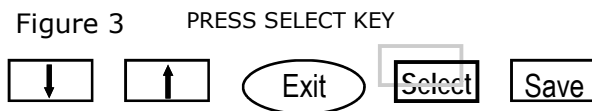
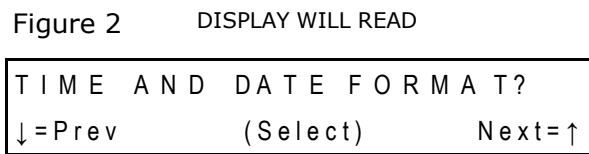
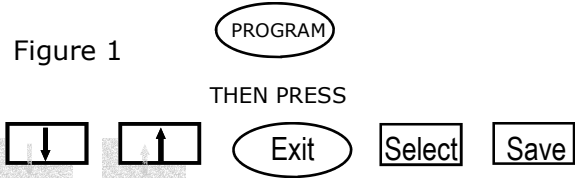
```
VM Seconds of Wait:  
90 Seconds (Save)
```

# Programming

## Programming Time and Date

1. Press the **"PROGRAM"** key (Figure 1). Press the **"UP"** or **"DOWN"** key until the display shows **"TIME AND DATE FORMAT?"** (Figure 2).
2. To activate, press the **"SELECT"** key (Figure 3).
3. There are six different format options (Figure 4) plus the option to disable time and date.
4. When the desired format is displayed on the LCD screen, press the **"SAVE"** key.
5. By pressing **"UP"**, the screen **"TIME AND DATE SET?"** will appear (Figure 5).
6. Press **"SELECT"**.
7. Enter the Date and Time. Time can be entered as a 12-hour or 24-hour clock. In the 12-hour format, press 2 for "AM" or 7 for "PM" (Figure 6).
8. Press **"EXIT"** to exit the program mode or press **"UP"** or **"DOWN"** to continue scrolling through the program mode.

Default format is MMM DD hh:mm  
or JAN 01 08:00

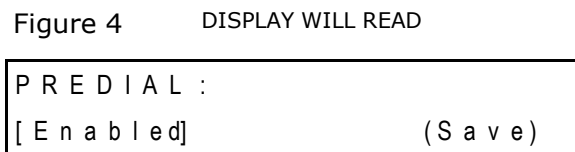
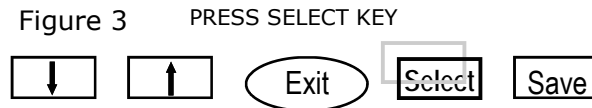
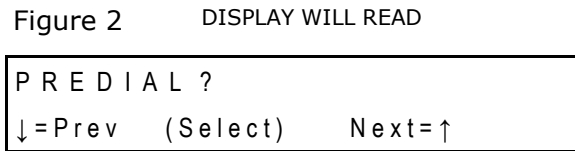
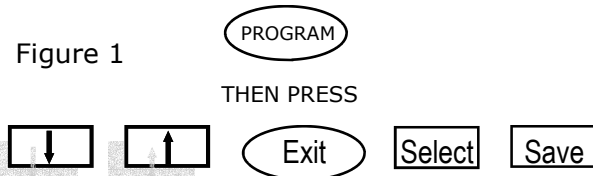


# Programming

## Programming Pre-dial

When Pre-dial is enabled, the keypad can be used to dial while the telephone is ON HOOK. After pre-dialing, lift the handset, or press the speaker key, or press the headset key within 12 seconds to place the outgoing call.

1. Press the **"PROGRAM"** key (Figure 1). Press the **"UP"** or **"DOWN"** key until the display shows **"PREDIAL?"** (Figure 2).
2. Press the **"SELECT"** key (Figure 3).
3. Enable will be displayed on the LCD. Press **"SAVE"** to enable pre-dial. To disable pre-dial, follow the same procedure (Figure 4).
4. Press **"EXIT"** to exit the program mode or press **"UP"** or **"DOWN"** to continue scrolling through the program mode.

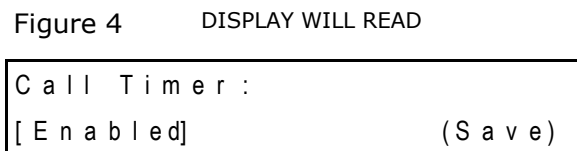
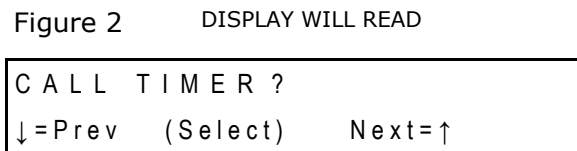
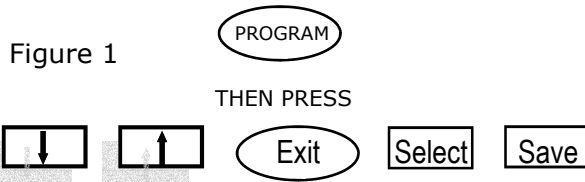


# Programming

## Programming Call Timer

When Call Timer is enabled, the LCD will display the elapsed time of an active call when the primary directory number is used.

1. Press the **"PROGRAM"** key (Figure 1). Press the **"UP"** or **"DOWN"** key until the display shows **"CALL TIMER?"** (Figure 2).
2. Press the **"SELECT"** key (Figure 3).
3. Enable will be displayed on the LCD. Press **"SAVE"** to enable Call Timer.
4. Press **"EXIT"** to exit the program mode or press **"UP"** or **"DOWN"** to continue scrolling through the program mode.



# Programming

## Programming Speakerphone Mode

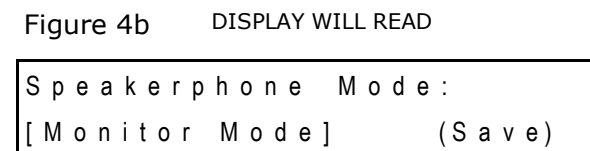
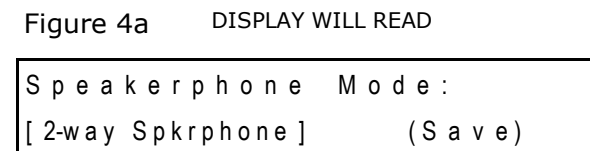
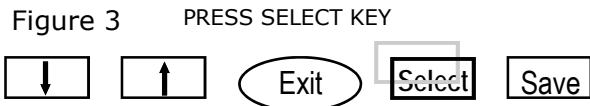
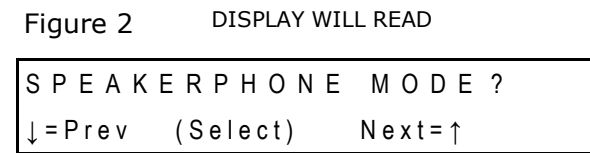
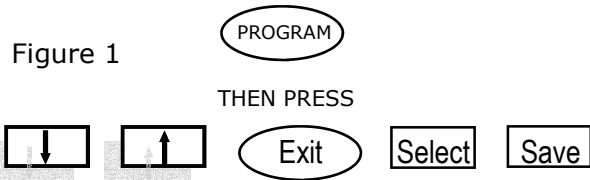
The DC550 includes an option for 2-way Speakerphone or Monitor Mode.

When "MONITOR MODE" is enabled, voice transmission automatically stops when the speakerphone key is pressed. MUTE will activate and the LED indicator will illuminate when the speakerphone is turned on through the **SPEAKER** key, or the LINE key, or from an incoming Intercom call. The MUTE feature will activate when the user switches from the handset or headset to the speakerphone during an active call.

When "MONITOR MODE" is enabled, the MUTE feature can be turned OFF to enable voice transmission on the speakerphone by pressing the MUTE key. If the directory numbers are switched or a call is placed on hold and then released, the MUTE feature will be reactivated.

The "2-WAY SPEAKERPHONE" option allows the voice to go out automatically to the speaker without muting voice transmission.

1. Press the "PROGRAM" key (Figure 1). Then, press the "UP" or "DOWN" key until the display shows "SPEAKERPHONE MODE?" (Figure 2).
2. Press the "SELECT" key (Figure 3).
3. Select 2-way Speakerphone to activate the speaker or select Monitor Mode to mute the speaker. Press "SAVE" (Figure 4).
4. Press "EXIT" to exit the program mode or press "UP" or "DOWN" to continue scrolling through the program mode.



# LCD Display

## **LCD FEATURES**

The Spectrum PLUS™ LCD display is a 2-lines x 24-character backlit display with contrast adjustments. The LCD will display the identity of the caller and the time of the call. The user has the option to answer the call or allow the call to automatically be forwarded to voice mail.

## **LCD BACKLIGHT FEATURE**

The Spectrum PLUS™ is equipped with a blue backlit Liquid Crystal Display (LCD) that enhances visibility of the LCD.

## **LCD DISPLAY INFORMATION**

The LCD displays information that is provided by the Nortel Meridian PBX or Central Office. Information that is displayed on the LCD is provided by the PBX or Central Office. The LCD will display this information when an incoming call comes in.

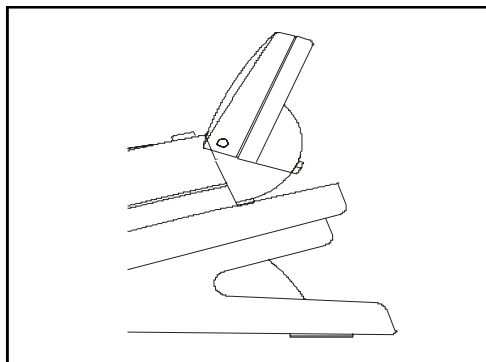
# LCD Display

## Caller Identification (Caller ID) LCD Display Adjustments

### LCD TILT ANGLE FEATURE

The LCD can be tilted upward for direct viewing and easy reading. Tilt the LCD to the desired position by lifting up the back of LCD housing (Figure 1).

(60° maximum upward tilt).



### LCD CONTRAST FEATURE (16-step)

The LCD characters can be lightened or darkened using the contrast UP/DOWN keys (Figure 2).

While the handset is in the ON HOOK position, simply press the UP or DOWN keys to adjust the contrast of the LCD screen. There are 16 contrast step adjustments (Figure 3).

To lighten characters, press the "UP" key.

To darken characters, press the "DOWN" key.

*The display will clear 3 seconds after the last key press or after pressing the EXIT key.*

Figure 2

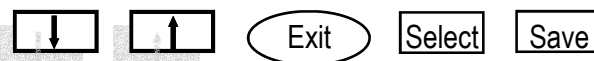


Figure 3 PRESS THE UP OR DOWN KEYS



# LCD Display

## MEMORY DIAL KEY

The Memory Dial key allows access to the Memory for programmed numbers. Toggle between different Memory Dial numbers when pressing the Memory Dial key, the "UP" or "DOWN" keys, or the dial pad keys. When the memory location is found, go off hook by lifting the handset or pressing the Headset On/Off or Speaker keys within 12-seconds to activate that memory dial number.

## Retrieving and Dialing Stored Memory Records

1. Press the "MEMORY" key (Figure 1).

Figure 1

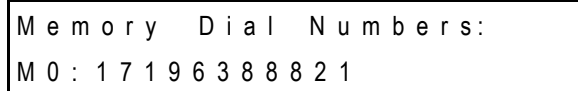


2. Press the "UP" or "DOWN" key until the display reads the number or memory location wanted or press the numeric location using the keypad (Figure 2).

Figure 2 PRESS UP or DOWN KEY

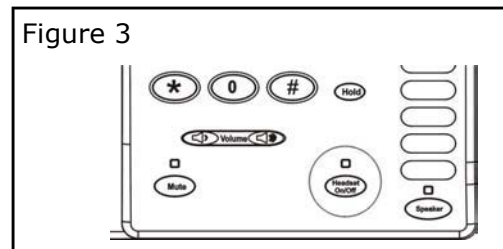


Figure 2 SEARCH FOR MEMORY LOCATION



3. To activate dialing, lift the handset, or press the "SPEAKER" key or "HEADSET ON/OFF" key (Figure 3).

Figure 3



## Deleting/Changing a Stored Memory Record

To delete or change a stored memory location, press "PROGRAM", and scroll to "MEMORY DIAL NUMBER?". Use the UP/DOWN keys to find the record to delete. When found, press "SELECT", then "SAVE" to delete the number. To save a new number in a memory location, scroll to that location, press "SELECT", then enter the new number. To save the new number, press "SAVE" and then press "EXIT". To avoid deleting the record, press the "EXIT" key *PRIOR* to entering a new number.

# Headset

## Headset Feature

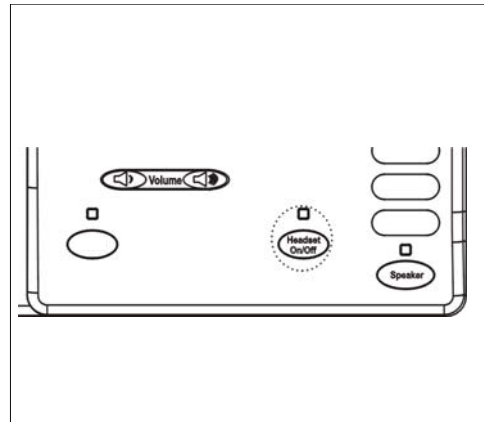
The Spectrum PLUS™ is equipped with a separate port for plugging in an optional headset. The port is located on the bottom of the base unit. The TeleMatrix **FreeSpeech™ Talk Feature** is a unique TeleMatrix feature that allows the user the freedom to toggle between the headset, handset and speakerphone modes during a conversation.

When the “**HEADSET ON/OFF**” key is ON, pressing the “**SPEAKER**” key will activate the speaker and disconnect the headset line automatically. This feature avoids having to use the hook switch/handset to process telephone calls while in headset mode.

The headset can be purchased from a TeleMatrix distributor. There are many varieties of headset models available.

## Installing a Headset

- The headset port is located on the bottom side of the telephone base.
- Plug the modular end of the headset cord into the modular port of the telephone labeled “HEADSET” (figure 1).
- Press the “HEADSET ON/OFF” key to activate the headset. The LED above the key will illuminate to indicate that the headset is on (figure 2).



**NOTE:** When using a direct-connect headset, an external amplifier is NOT recommended because the phone has a built in amplifier.

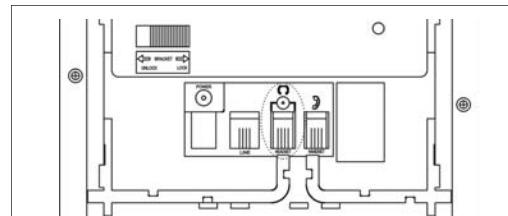


Figure 1

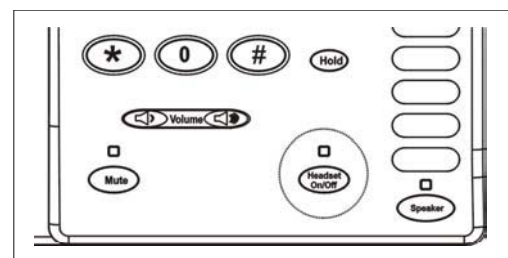


Figure 2

# Headset

## Using A Headset

The “**HEADSET ON/OFF**” key controls the activation of the Headset. When using the headset feature, the handset remains on-hook at all times.

## Placing/Answering a Call using the Headset On/Off Feature

- To answer an incoming call, press the “**HEADSET ON/OFF**” key to activate the headset. The LED above the “**HEADSET ON/OFF**” key will be illuminated when in ON position.
- Adjust the volume, if necessary.
- Use the control features of the headset that are available to you.
- You can dial using the keypad or a provisioned advance feature key.
- To end headset activation, press the “**HEADSET ON/OFF**” key. The LED above the “**HEADSET ON/OFF**” key will not be lighted when in OFF position.



**Volume Lock Feature** — When the handset, speaker, ringer or headset volume is adjusted, the volume will automatically stay at that setting in the next use.



**FreeSpeech™ Talk Feature** is a unique TeleMatrix feature that allows the user the freedom to toggle between the headset, handset and speakerphone modes during a conversation.

# Operation

## **PREDIALING FEATURE**

When programmed, the telephone supports a pre-dialing feature for calls made on the Primary Directory Number, or the line corresponding to Feature Key 1 (directly above the Speaker key). The pre-dial feature allows users to enter a number before lifting the handset or using the headset or speakerphone for an outgoing call. The user can enter up to 20-digits, which are dialed if the user lifts the handset or presses the Headset On/Off or Speaker keys within 12-seconds of dialing the last digit.

## **RELEASE KEY FEATURE**

The **"RLS"** (RELEASE) key is a hard line break. When pressed the key automatically disconnects an existing active line. There is no dial tone after the **"RLS"** key is pressed.

To use, simply press the **"RLS"** key when a conversation is complete.

## **VOLUME CONTROL (Ring, Speaker, Headset, Handset)**

The Spectrum PLUS™ DC550 is equipped with an ADA/FCC compliant volume control located on the front of the phone.

To adjust the volume, press the right end of the **"VOLUME"** key and the volume is increased. When the left end of the **"VOLUME"** key is pressed, the volume is decreased.

The **"VOLUME"** key is a sixteen-step volume control.

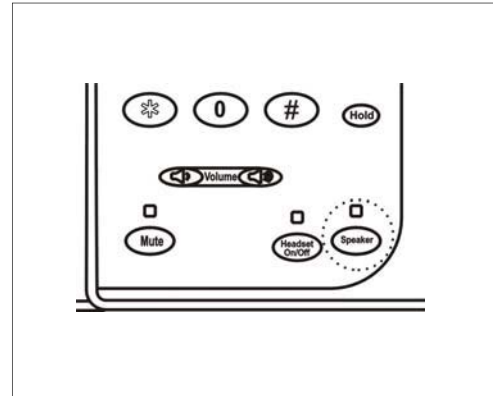
# Operation

## SPEAKERPHONE FEATURE

The Spectrum PLUS™ is equipped with a high quality half-duplex speakerphone feature to allow for hands-free operation. To use, simply press the **"SPEAKER"** key when placing or answering a call. The primary directory line will activate automatically.

The LED above the **"SPEAKER"** key will illuminate to indicate that the speakerphone is in-use.

To disconnect, simply press the **"SPEAKER"** key or **"RLS"** key.



**Note:** Use the VOLUME BAR to adjust the volume of the speaker.

**Note:** Use the MUTE key during conference calls to reduce background noise.

## POWER FAILURE

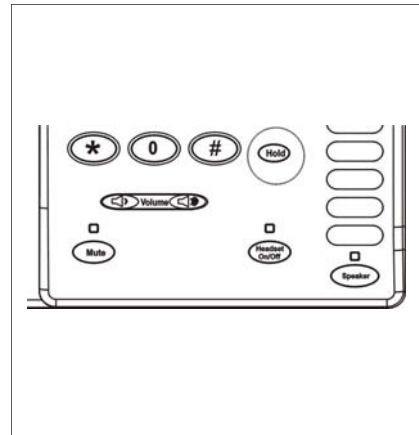
During any power failure only two feature key LED's will work. They are keys 1 and two in the first row of keys.

# Operation

## HOLD FEATURE

The **"HOLD"** key is used to place a caller on hold. To use, simply press the **"HOLD"** key.

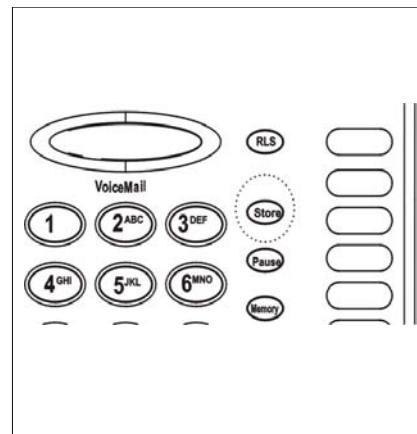
When the **"HOLD"** key is active, the handset can be lifted off-hook or returned to its on-hook position and the line will not be disconnected. To return to the caller, simply lift the handset or activate the speaker key and press the blinking line key.



## STORE FEATURE

The DC550 has a Store feature which allows a user to store a dialed number of up to 20-digits before hanging up during a conversation. Afterwards, the stored number will be retrieved if the user presses the **STORE** key while in the Idle state. The stored digits would then populate the first line and be treated in the same manner as pre-dialed digits.

Although the user will only be able to pre-dial or use the stored digits for calls on the Primary Directory Number, he or she will be able to store digits dial ed on any outgoing line.

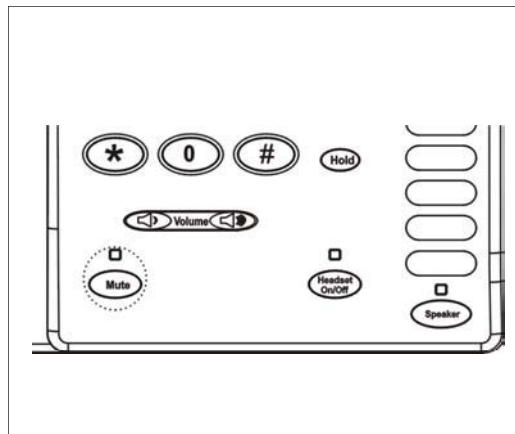


# Operation

## MUTE FEATURE

A **"MUTE"** key is provided to allow privacy during a background conversation. When the **"MUTE"** key is activated, the microphones in the handset, speakerphone and/or the headset are disabled. When the **"MUTE"** key is activated, the party on the other end of the line will not hear voice. To de-activate, press the **"MUTE"** key again.

Note: if the mute feature is automatically activated each time the speakerphone is enabled, the phone may be configured in monitor mode.

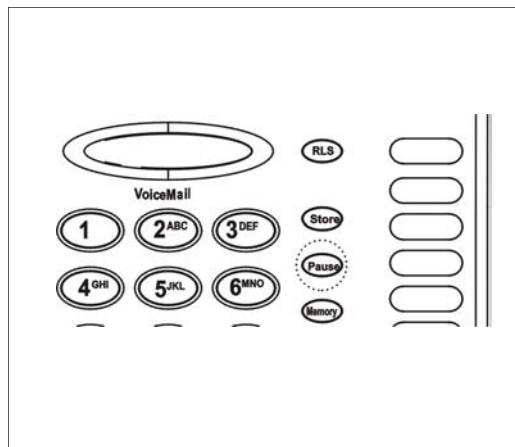


## PAUSE KEY FEATURE

A **"PAUSE"** key is provided to insert a 1.0-second time break when dialing from the keypad or memory location.

A multiple of **"PAUSE"** keys can be dialed or programmed into memory of a caller record.

Each pause key counts as one (1) digit when programmed into memory. When programming into memory or dialing, simply press the pause key in the appropriate dialing pattern.



# Operation

## Business Feature Keys

Advanced feature keys are programmed by your Telephone System Administrator or Telephone Service Personnel. These features are provided by the telephone company in a Nortel Digital Centrex environment. Only some of the features listed will be available to you because each telephone is customized to a specific business application.

Auto Callback	Activates the Camp-On feature. Allows the attendant to extend an incoming call to a busy station and the caller the option of continuing to wait.
Auto Dial	Autodial feature permits an attendant to dial frequently called numbers by pressing the Auto-dial feature key.
Auto Line	Provides an automatic connection between a calling station that goes off-hook and a predetermined location.
Call Fwd	Activates the Call Forward feature that is provisioned in the Central Office.
Call Park	Activates the Call Park feature. Allows the user to park a call.
Call Wait	Activates the Call Waiting feature. An audible signal is heard when the phone is in-use.
Conf	Activates the 3-way Conference feature.
Conf 3	Similar to Conf, but with a maximum of 3 ports.
Conf 6	Similar to Conf, but with a maximum of 6 ports.
Conf/Transfer	Activates the 3-way Conferencing/Transfer feature.
Cwt Cancel	Allows a station user to prevent, on a per-call basis, any incoming calls from call waiting.
DND	Do Not Disturb. Also see Make Busy.
Dir Pickup	Permits a station to answer a call that is ringing any line within an assigned group.
Drop	Allows user to drop a call on hold. Suggest to use the Release Key.
End-to-End	Activates the End to End feature.
Hunt	Activates the hunting features. Hunting increases likelihood of the call being receive within an assigned group.
I/C	Activates Intercom feature (to a specific station).
I/C Group	Activates Intercom Group feature (to a group of stations).
Inspect	Allows user access to information about the set's assigned features and incoming calls.
Leave Msg	Allows the user to leave or retrieve messages.
Make Busy	Allows for the set to be made busy to incoming calls. Can use the DND label.
Override	Activates the Busy Override feature. Allows set to gain access to a busy station.
Page	Activates the Page feature for getting access to a loudspeaker paging system.
Pickup	Activates the Call Pickup feature to allow a station to pick up a call.
Pwr Features	Multiple features adds a variety of C.O. provisioning services.
Privacy	Activates the Privacy feature.
Priv Rls	Deactivates the Privacy feature.
Query Busy	Allows a stations to query the busy/idle status of one designated station within a group.
Redial	Activates the Redial feature to allow for last called number dialing.
Ring Again	Activates the Ring Again feature. Notifies the calling party when the station becomes free.
Spd Call	Activates speed calling and gains access to memorized group lists.
Time/Date	Displays the time and date for 12 seconds. Must be provisioned.
Transfer	Activates the Transfer feature to transfer a call to another station.
UCD	Enhances the capabilities of Uniform Call Distribution (UCD).
Wake	Activates the Wake Up reminder call services .

Note: Preprinted labels with the above featured names were provided in the original box.

# Operation

## ACD Call Center Feature Keys

Agent	Allows ACD Supervisor to select the Agent to call when using the Call Agent feature or enables the ACD Supervisor to check the status of all ACD Agent positions when using the Display Agent Feature.
Agent Avail	Allows the ACD Supervisor to require an Agent to receive available incoming calls, even though the Agent has pressed the Not Ready key.
Agt Status	Allows supervisor to monitor an Agent's status. Recommend Display Queue Status.
Ans Agent	Allows supervisor to receive a ring back when a Agent is calling the Supervisor.
Ans Emergency	Allows supervisor to immediately answer emergency calls from Agents who have the Emergency key.
Call Agent	Allows supervisor to call an Agent directly.
Call Supv	Allows the Agent to call the Supervisor directly.
Dis Agt Sum	Allows supervisor to view Agent activity in ACD group.
Disp Queue	Allows supervisor or Agent to view ACD queue status.
EMK	Allows Agent to immediately conference and/or record abusive calls.
Emergency	Same as EMK. Reports an abusive or threatening call to supervisor.
Flex Call	Allows deactivation of conference caller to smaller group.
Force Call	Can also use the Release key.
In Calls	Allows Agent to answer Primary Directory calls using the first key on the set.
Interflow	Allows Supervisor to reroute incoming calls from one ACD group to another.
LOB	Agent enters a three (3) digit code to record the nature of the call for line of business reporting.
MCH	Activates the "Malicious Call Hold" feature.
Night Serv	Allows supervisor to enable or disable Night Service handling.
Not Ready	Allow agent to follow up on a transaction without being interrupted by the next call.
Obs Agent	Allows supervisor to monitor a conversation between an Agent and an ACD caller.
Park	Activates the Call Park feature.
Pwr Features	Multiple features adds a variety of C.O. provisioning services.
Queue	Prioritizes incoming calls in a queue by order of arrival.
Queue Status	Allows Supervisor to monitor the queue status of an ACD group.
Supervisor	Allows Agent to select a supervisor to call.
Transfer	Activates the Call Transfer feature.

Note: Preprinted labels with the above featured names were provided in the original box.

# Care and Maintenance



Keep the telephone dry. If it gets wet on the outside, wipe it dry immediately. Liquids might contain minerals that can corrode the electronic circuits. Do not touch the unit if submerged in water. Call for assistance.



Use and store the telephone only in normal temperature environments. Temperature extremes can shorten the life of electronic devices, damage batteries, and distort or melt plastic parts. Avoid direct sunlight.



Keep the telephone a way from excessive dust and dirt that can cause premature wear of parts.



Wipe the telephone with a damp cloth occasionally to keep it looking new. Do not use harsh chemicals, cleaning solvents, or strong detergents to clean the unit.

# Service

When problems arise during installation or service that cannot be resolved using this or related documents, contact the TeleMatrix Priority Care Department, Monday through Friday, 8:30a. m. - 4:30p. m. MST:

Toll Free: 1-800-462-9446  
Direct: 719-638-8821  
Fax: 719-638-8815

www.telematrixusa.com

Many times a problem is either installation or user related. Please contact TeleMatrix PRIOR to sending a telephone to our service center for repair. In the unlikely event that a factory repair is necessary:

1. Include a brief description of the problem that you are experiencing.
2. Include a proof of purchase for a repair under warranty.
3. Send the telephone prepaid by UPS or Parcel Post, insured to:

TeleMatrix, Inc.  
Priority Care Center  
5025 Galley Road  
Colorado Springs, Colorado 80915

TeleMatrix will pay return postage on the repaired telephone. Allow 2-3 weeks for delivery. When immediate replacement is required, see our FastLane<sup>SM</sup> replacement policy on our internet site.

# Warranty

## STATEMENT OF LIMITED WARRANTY

TeleMatrix, Inc. (TMX) warrants to its [original end customer] [purchaser] that Spectrum and Marquis branded products manufactured by TMX are free from defects in materials and workmanship for (5) years and Spectrum PLUS for (2) years after the date of purchase, and Regency branded products manufactured by TMX are free from defects in materials and workmanship for (3) years, other than the following products for which the warranty period shall be one (1) year: handset batteries, either NiCd or NiMH, used in TMX cordless products. If a product fails this warranty during the warranty period, TMX will, at its option, either repair or replace the defective product or parts, or deliver replacements for defective products or parts on an exchange basis at no additional charge to the customer except as set forth below. Repair parts or replacement products may be either new or reconditioned. Products or parts returned to TMX under this warranty will become the property of TMX. Warranties on products repaired by TMX expire at the termination of the original warranty period.

This limited warranty does not cover:

1. Products or parts which are damaged, abused or misused;
2. Any damage resulting from improper installation, maintenance or operation of the product;
3. Damage resulting from unauthorized modification or repair of the product, or from improper connection of the product to other equipment;
4. Cords, connectors and replaceable batteries;
5. Damage in transit to the TMX repair facility;
6. Any product or part unless proof of date of purchase is submitted with the product when returned for warranty repair; or
7. Costs incurred by the customer in removing and shipping the product to TMX for repair or replacement, and costs of reinstallation of the product.
8. Products or parts which are not owned and used by the original end user customer.

The cost and risk of loss or damage for sending the product to TMX will be borne by the customer.

TMX EXPRESSLY DISCLAIMS ALL WARRANTIES EXCEPT THE LIMITED WARRANTY SET FORTH HEREIN, WHICH IS THE SOLE AND EXCLUSIVE WARRANTY OF THE PRODUCT, AND IS IN LIEU OF ALL OTHER WARRANTIES, WHETHER ORAL OR WRITTEN, EXPRESS OR IMPLIED, OR STATUTORY. THERE ARE NO IMPLIED WARRANTIES OF MERCHANTABILITY OR FITNESS FOR A PARTICULAR PURPOSE. THE CUSTOMER'S SOLE REMEDY UNDER THE TMX WARRANTY SHALL BE REPAIR OR REPLACEMENT AS PROVIDED ABOVE. IN NO EVENT WILL TMX BE LIABLE TO CUSTOMER OR ANY OTHER PARTY FOR ANY INDIRECT, INCIDENTAL OR CONSEQUENTIAL DAMAGES, INCLUDING, WITHOUT LIMITATION, DAMAGES OF LOST PROFITS, LOST REVENUES, LOSS OF USE OF FACILITIES OR EQUIPMENT, OR COST OF SUBSTITUTE EQUIPMENT ARISING OUT OF THE USE OR INABILITY TO USE THIS PRODUCT, EVEN IF THE CUSTOMER HAS ADVISED TMX OF THE POSSIBILITY OF SUCH DAMAGES. TMX LIABILITY FOR DAMAGES SHALL NOT EXCEED THE PURCHASE PRICE OF THE DEFECTIVE PRODUCT.

This limited warranty is non-transferable without the prior written approval of TMX. It gives the customer specific legal rights. The customer may have other rights which vary under local law. Some jurisdictions may not allow limitations on the term of an implied warranty or exclusions or limitations of incidental or consequential damages.



[www.telematrixusa.com](http://www.telematrixusa.com)  
1.800.462.9446

Product specifications and descriptions in this document: subject to change without notice.  
©TeleMatrix Inc. 2002

TeleMatrix is a trademark, TouchLite and SteelTrap are registered trademarks, PriorityCare, FastLane and morePhone are service marks of TeleMatrix, Inc.